

Ultralow-Power SC70/SOT-323 Packaged 50mA LDO Linear Regulators with Power Good Output

FEATURES

- 50mA Low-Dropout Regulator
- Ultralow 1.2 μ A Quiescent Current at 10mA
- 5-Pin SC70/SOT-323 (DCK) Package
- Integrated Power Good Output
- Stable With Any Capacitor ($> 0.47\mu$ F)
- Dropout Voltage Typically 105mV at 10mA (TPS79733)
- Over Current Limitation
- -40°C to $+85^{\circ}\text{C}$ Operating Junction Temperature Range

APPLICATIONS

- Battery-Powered Microcontrollers and Microprocessors

DESCRIPTION

The TPS797xx family of low-dropout (LDO) voltage regulators offers the benefits of low-dropout voltage and ultralow-power operation. The device is stable with any capacitor ($> 0.47\mu$ F). Therefore, implementations of this device require very little board space due to the miniaturized packaging and potentially small output capacitor. In addition, the family includes an integrated open drain active-high power good (PG) output. Intended for use in microcontroller-based, battery-powered applications, the TPS797xx family's low dropout and ultralow-powered operation results in a significant increase in system battery operating life. The small packaging minimizes consumption of board space.

The device is enabled when the applied voltage exceeds the minimum input voltage. The usual PNP pass transistor has been replaced by a PMOS pass element. Because the PMOS pass element behaves as a low-value resistor, the dropout voltage is very low, typically 105mV at 10mA of load current, and is directly proportional to the load current. The quiescent current is ultralow (1.2 μ A typically) and is stable over the entire range of output load current (0mA to 50mA). When properly configured with a pull-up resistor, the PG output can be used to implement a power-on reset or low battery indicator. The TPS797xx is offered in 1.8V, 3V, and 3.3V fixed options.

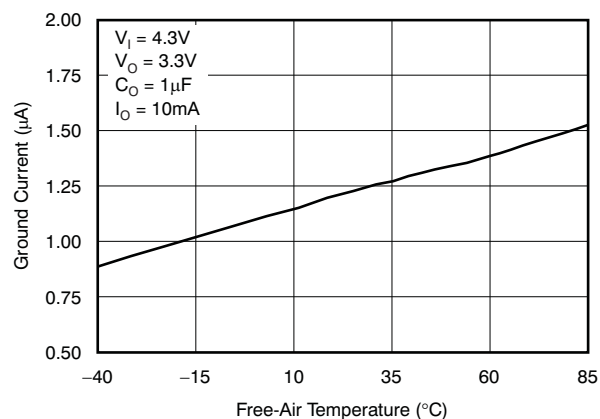
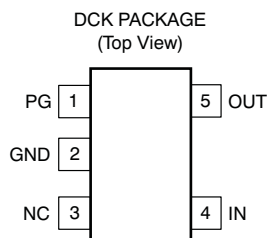

Please be aware that an important notice concerning availability, standard warranty, and use in critical applications of Texas Instruments semiconductor products and disclaimers thereto appears at the end of this data sheet.

All trademarks are the property of their respective owners.



This integrated circuit can be damaged by ESD. Texas Instruments recommends that all integrated circuits be handled with appropriate precautions. Failure to observe proper handling and installation procedures can cause damage.

ESD damage can range from subtle performance degradation to complete device failure. Precision integrated circuits may be more susceptible to damage because very small parametric changes could cause the device not to meet its published specifications.

ORDERING INFORMATION⁽¹⁾

PRODUCT	V _{OUT} ⁽²⁾
TPS797xxyyyz	XX is nominal output voltage (for example, 25 = 2.5V, 01 = Adjustable ⁽³⁾). YYY is package designator. Z is package quantity.

- (1) For the most current package and ordering information see the Package Option Addendum at the end of this document, or see the TI web site at www.ti.com.
- (2) Output voltages from 1.25V to 4.9V in 50mV increments are available through the use of probe level programming; minimum order quantities may apply. Contact factory for details and availability.
- (3) For fixed 1.2V operation, tie FB to OUT.

ABSOLUTE MAXIMUM RATINGS

Over operating junction temperature range, unless otherwise noted.⁽¹⁾

Input voltage range ⁽²⁾	–0.3V to 6V
Maximum dc output voltage	4.9V
Peak output current	Internally limited
ESD rating, HBM	2kV
ESD rating, CDM	500V
Continuous total power dissipation	See Dissipation Ratings Table
Operating virtual junction temperature range, T _J	–40°C to +85°C
Storage temperature range, T _{STG}	–65°C to +150°C

- (1) Stresses beyond those listed under *absolute maximum ratings* may cause permanent damage to the device. These are stress ratings only, and functional operation of the device at these or any other conditions beyond those indicated under *recommended operating conditions* is not implied. Exposure to absolute-maximum-rated conditions for extended periods may affect device reliability.
- (2) All voltage values are with respect to network ground terminal.

PACKAGE DISSIPATION RATINGS

BOARD	PACKAGE	R _{θJC} °C/W	R _{θJA} °C/W	DERATING FACTOR ABOVE T _A = +25°C	T _A ≤ +25°C POWER RATING	T _A = +70°C POWER RATING	T _A = +85°C POWER RATING
Low K ⁽¹⁾	DCK	165.39	396.24	2.52mW/°C	252mW	139mW	101mW
High K ⁽²⁾	DCK	165.39	314.74	3.18mW/°C	318mW	175mW	127mW

- (1) The JEDEC low K (1s) board design used to derive this data was a 3-inch × 3-inch, two layer board with 2 ounce copper traces on top of the board.
- (2) The JEDEC high K (2s2p) board design used to derive this data was a 3-inch × 3-inch, multilayer board with 1 ounce internal power and ground planes and 2 ounce copper traces on top and bottom of the board.

ELECTRICAL CHARACTERISTICS

Over operating temperature range $T_J = -40^{\circ}\text{C}$ to $+125^{\circ}\text{C}$, $V_{IN} = V_{OUT}$ (typ) $+0.5\text{V}$ or 2.0V , whichever is greater; $I_{OUT} = 0.5\text{mA}$, V_{SET} , $V_{EN} = V_{IN}$, and $C_{OUT} = 1.0\mu\text{F}$, unless otherwise noted. Typical values are at $T_A = +25^{\circ}\text{C}$.

PARAMETER		TEST CONDITIONS	TPS797xx			UNIT
			MIN	TYP	MAX	
V_{IN}	Input voltage ⁽¹⁾	$I_{OUT} = 3\text{mA}$	1.8		5.5	V
		$I_{OUT} = 10\text{mA}$	2		5.5	
I_{OUT}	Continuous output current ⁽²⁾		0		50	mA
V_{OUT}	Output voltage accuracy ⁽³⁾	$V_{OUT} + 1\text{V} \leq V_{IN} \leq 5.5\text{V}$ $10\mu\text{A} < I_{OUT} < 10\text{mA}$	-4		4	%
$\frac{\Delta V_{OUT}\%}{\Delta V_{IN}}$	Line regulation ⁽³⁾	$V_{OUT} + 1\text{V} \leq V_{IN} \leq 5.5\text{V}$		0.15	0.8	%/V
$\frac{\Delta V_{OUT}\%}{\Delta I_{OUT}}$	Load regulation	$1\mu\text{A} < I_{OUT} < 10\text{mA}$		5		mV
V_{DO}	Dropout voltage ⁽⁴⁾ , $I_{OUT} = 10\text{mA}$ $V_{IN} = V_{OUT}(\text{NOM}) - 0.1\text{V}$	TPS79730		110	200	mV
		TPS79733		105	200	
I_{SC}	Output current limit	$V_{OUT} = 0\text{V}$		190	300	mA
I_{GND}	Ground pin current ⁽³⁾	$I_{OUT} = 10\text{mA}$		1.2	2	μA
PSRR	Power-supply rejection ratio (ripple rejection)	$f = 100\text{Hz}$, $C_{OUT} = 10\mu\text{F}$, $I_{OUT} = 10\text{mA}$		50		dB
V_N	Output noise voltage (TPS79718)	$\text{BW} = 200\text{kHz}$ to 100kHz , $C_{OUT} = 10\mu\text{F}$, $I_{OUT} = 10\text{mA}$		600		μV_{RMS}
$V_{PG(\text{MIN})}$	Minimum input voltage for valid PG	$V_{(\text{PG})} \geq 0.8\text{V}$, $I_{\text{PG}} = 100\mu\text{A}$		1.2		V
V_{IT}	PG trip threshold voltage	V_{OUT} decreasing	82	90	96	%/V _{OUT}
$V_{\text{PG,LO}}$	PG output low voltage	$V_{IN} = 1.5\text{V}$, $I_{\text{PG}} = 90\mu\text{A}$		0.14	0.225	V
$I_{\text{PG,LKG}}$	PG leakage current	$V_{(\text{PG})} = 5\text{V}$,	0.1			nA
T_J	Operating junction temperature, T_J		-40		+85	$^{\circ}\text{C}$

(1) Minimum $V_{IN} = V_{OUT} + V_{DO}$ or the minimum value specified here, whichever is greater.

(2) Continuous output current is limited by internal protection circuitry, but it is not recommended that the device operate above this maximum for extended periods of time.

(3) Minimum V_{IN} is specified in note (1).

(4) V_{DO} is not measured for the TPS79718 because minimum $V_{IN} > 1.7\text{V}$.

FUNCTIONAL BLOCK DIAGRAM

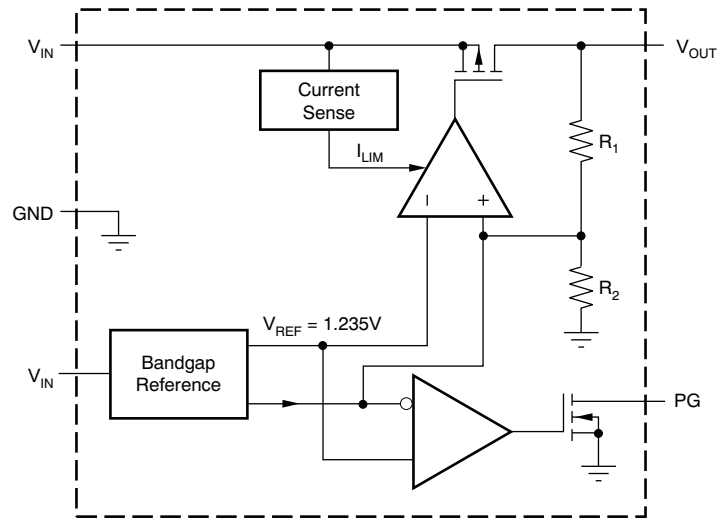
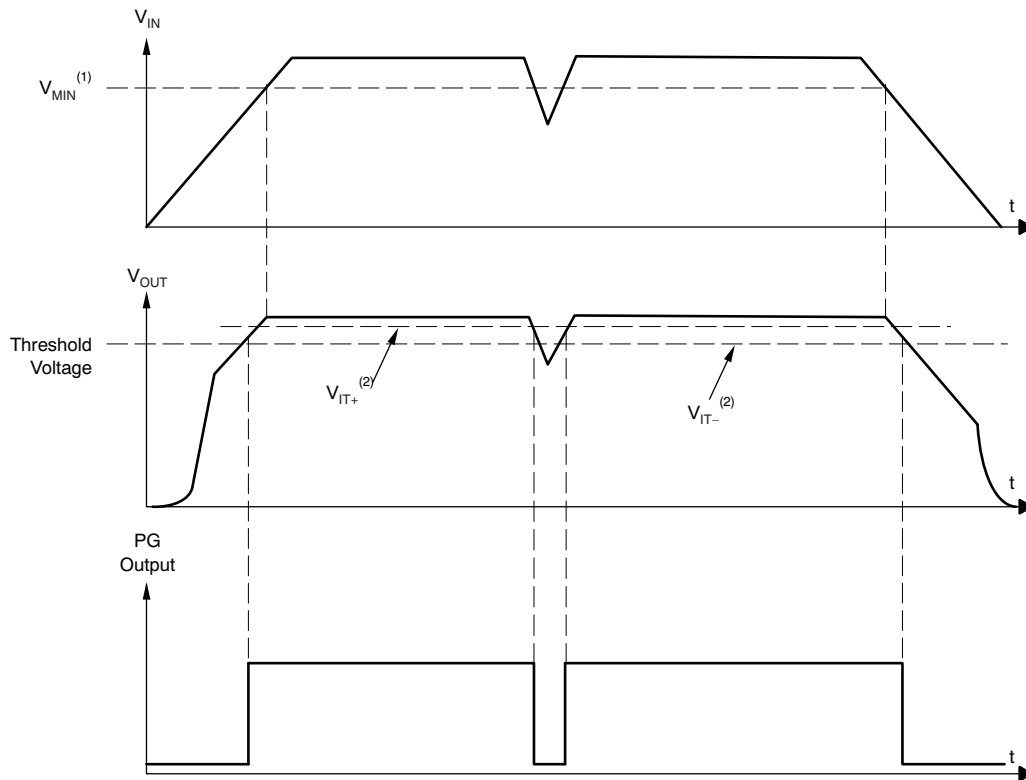

Table 1. TERMINAL FUNCTIONS

TERMINAL		DESCRIPTION
NAME	NO.	
GND	2	Ground
NC	3	No connection
OUT	5	The OUT terminal provides the regulated output voltage of the device.
PG	1	The PG terminal for the fixed voltage option devices is an open drain, active-high output that indicates the status of V_O (output of the LDO). When V_O exceeds approximately 90% of the regulated voltage, PG goes to a high-impedance state. It goes to a low-impedance state when V_O falls below approximately 90% (that is, overload condition) of the regulated voltage. The open drain output of the PG terminal requires a pull-up resistor.
IN	4	The IN terminal is the power supply input to the device.

TPS797xx PG Timing Diagram



NOTES: (1) $V_{MIN} = V_{OUT} + V_{DO}$.
 (2) The PG trip voltage is typically 10% lower than the output voltage (90% V_O). V_{IT+} to V_{IT-} is the hysteresis voltage.

TYPICAL CHARACTERISTICS

OUTPUT VOLTAGE
 vs
 OUTPUT CURRENT

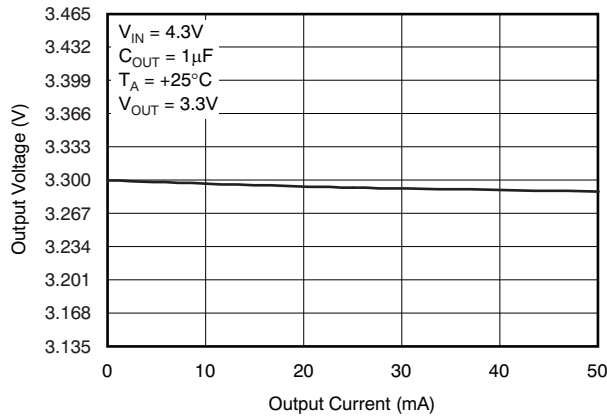

Figure 1.

OUTPUT VOLTAGE
 vs
 OUTPUT CURRENT

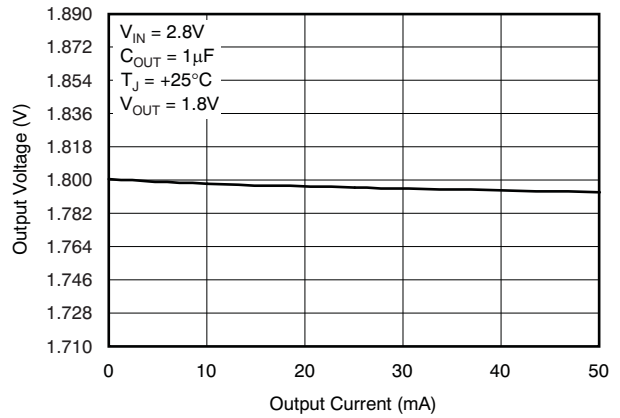

Figure 2.

OUTPUT VOLTAGE
 vs
 JUNCTION TEMPERATURE

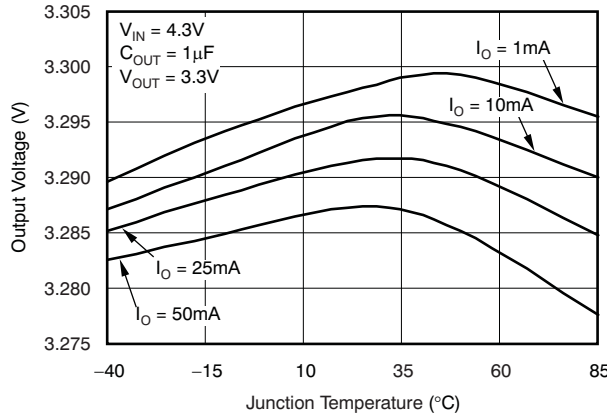

Figure 3.

OUTPUT VOLTAGE
 vs
 JUNCTION TEMPERATURE

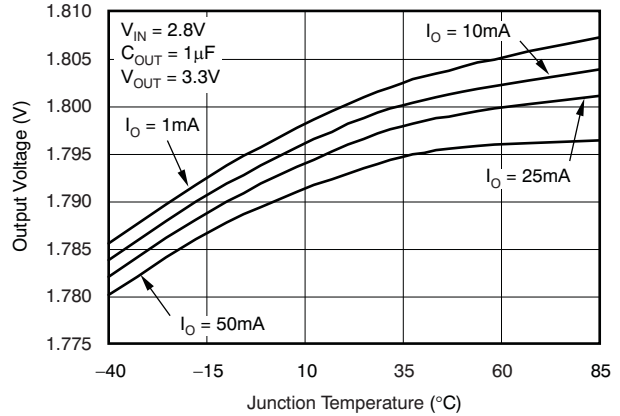

Figure 4.

GROUND CURRENT
 vs
 JUNCTION TEMPERATURE

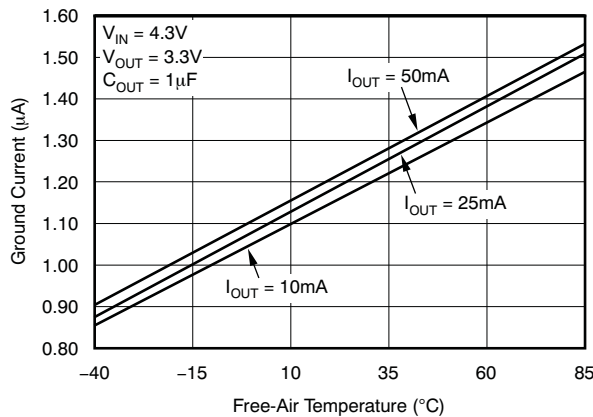

Figure 5.

OUTPUT SPECTRAL NOISE DENSITY
 vs
 FREQUENCY

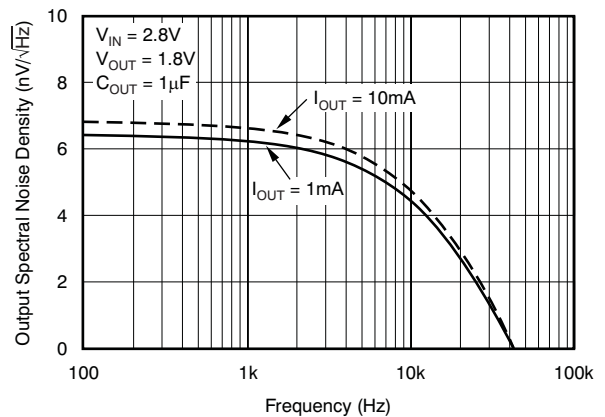

Figure 6.

TYPICAL CHARACTERISTICS (continued)

**OUTPUT IMPEDANCE
vs
FREQUENCY**

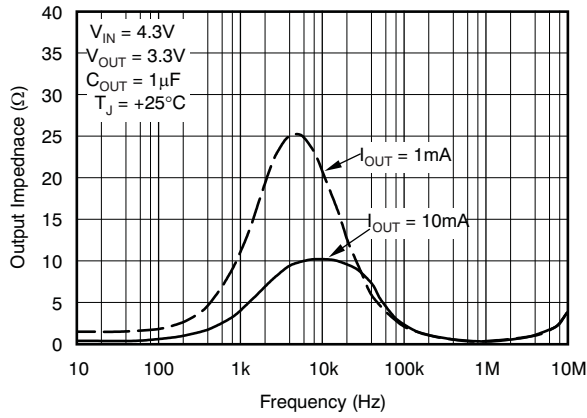

Figure 7.

**DROPOUT VOLTAGE
vs
JUNCTION TEMPERATURE**

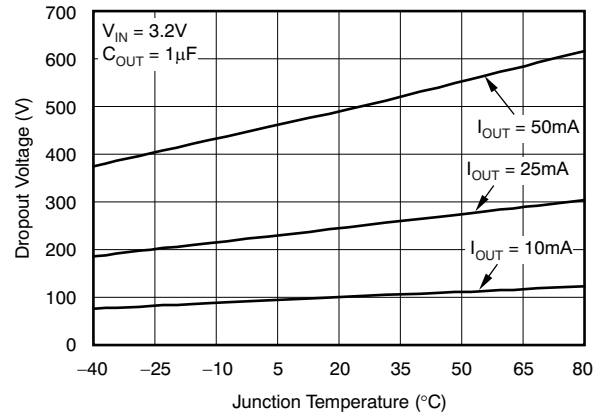

Figure 8.

POWER-UP/POWER-DOWN

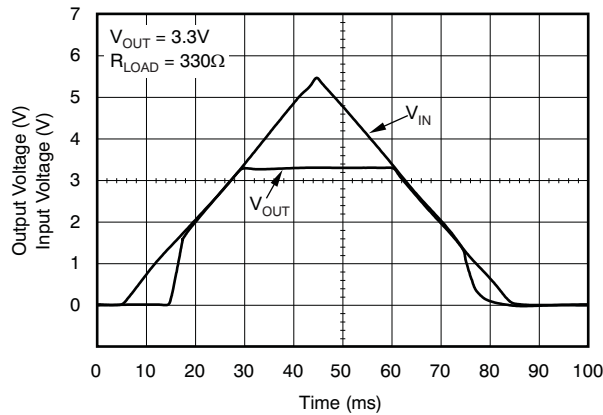

Figure 9.

TPS79718 LINE TRANSIENT RESPONSE

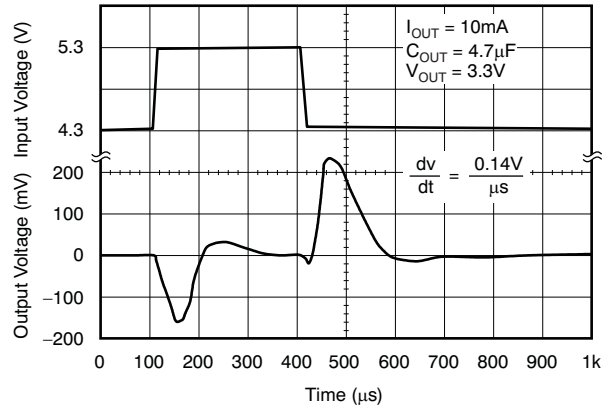

Figure 10.

TPS79718 LOAD TRANSIENT RESPONSE

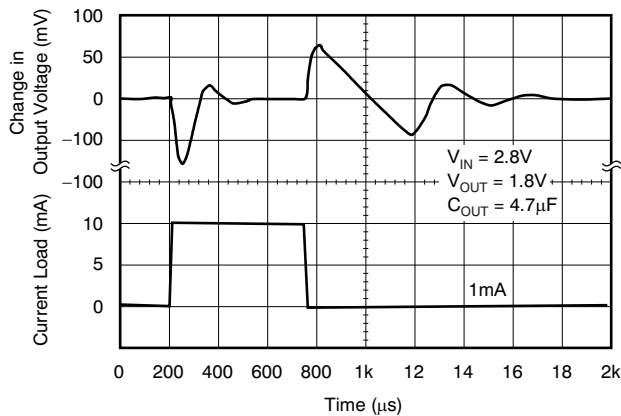

Figure 11.

TPS79733 LINE TRANSIENT RESPONSE

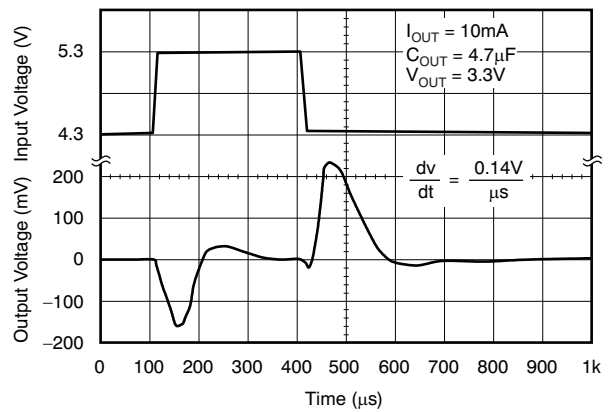

Figure 12.

TYPICAL CHARACTERISTICS (continued)

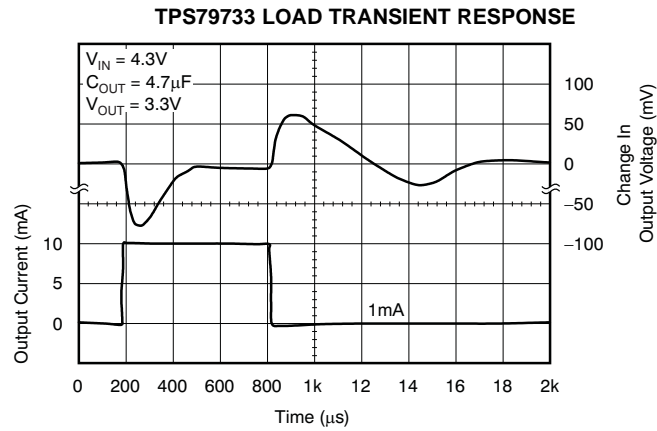

Figure 13.

APPLICATION INFORMATION

The TPS797xx family of low-dropout (LDO) regulators have been optimized for use in micropower applications. They feature extremely low dropout voltages and ultralow quiescent current (1.2µA typically).

A typical application circuit is shown in [Figure 14](#).

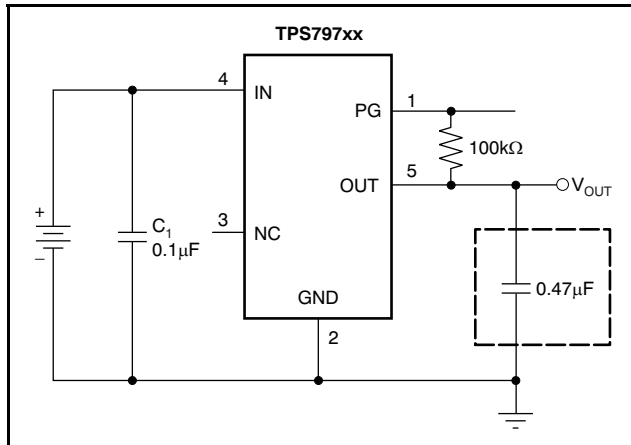

Figure 14. Typical Application Circuit

External Capacitor Requirements

Although not required, a 0.1µF or larger input bypass capacitor, connected between IN and GND and located close to the TPS797xx, is recommended, especially when a highly resistive power supply is powering the LDO in addition to other devices. Like all low-dropout regulators, the TPS797xx requires an output capacitor connected between OUT and GND to stabilize the internal control loop. The minimum recommended capacitance is 0.47µF. Any 0.47µF capacitor is suitable. Capacitor values larger than 0.47µF are acceptable.

Power Dissipation and Junction Temperature

Specified regulator operation is assured to a junction temperature of +85°C; restrict the maximum junction temperature to +85°C under normal operating conditions. This restriction limits the power dissipation the regulator can handle in any given application. To ensure the junction temperature is within acceptable limits, calculate the maximum allowable dissipation, $P_{D(MAX)}$, and the actual dissipation, P_D , which must be less than or equal to $P_{D(MAX)}$.

The maximum-power-dissipation limit is determined using the following equation:

$$P_{D(max)} = \frac{T_{Jmax} - T_A}{R_{\theta JA}} \quad (1)$$

Where:

T_{Jmax} is the maximum allowable junction temperature.

$R_{\theta JA}$ is the thermal resistance junction-to-ambient for the package (see [Package Dissipation Ratings](#)).

T_A is the ambient temperature.

The regulator dissipation is calculated using:

$$P_D = (V_I - V_O) \times I_O \quad (2)$$

Power dissipation resulting from quiescent current is negligible. Excessive power dissipation triggers the thermal protection circuit.

Regulator Protection

The TPS797xx PMOS-pass transistor has a built-in back diode that conducts reverse current when the input voltage drops below the output voltage (for example, during power down). Current is conducted from the output to the input and is not internally limited. If extended reverse voltage operation is anticipated, external limiting might be appropriate.

The TPS797xx features internal current limiting. During normal operation, the TPS797xx limits output current to approximately 190mA. When current limiting engages, the output voltage scales back linearly until the overcurrent condition ends. Take care not to exceed the power dissipation ratings of the package.

Microcontroller Application

One application for which this device is particularly suited is providing a regulated input voltage and power good (PG) supervisory signal to low-power devices such as mixed-signal microcontrollers. The quiescent or ground current of the TPS797xx family is typically 1.2µA even at full load; therefore, the reduction in battery life by including the TPS797xx in the system is negligible.

The primary benefits of using the TPS797xx to power low-power digital devices include:

- Regulated output voltage that protects the device from battery droop and noise on the line (for example, switch bounce)
- Smooth, monotonic power up
- PG signal for controlled device $\overline{\text{RESET}}$
- Potential to use an existing 5V power rail to power a 3.3V or lower device
- Potential to provide separate digital and analog power and ground supplies for a system with only one power source

Figure 15 shows an application in which the TPS79718 is used to power TI's MSP430 mixed signal microcontroller.

Minimal board space is needed to accommodate the DCK (SC70/SOT-323) packaged TPS79718, the 0.1 μF output capacitor, the 0.47 μF input capacitor, and the pull-up resistor on the PG pin.

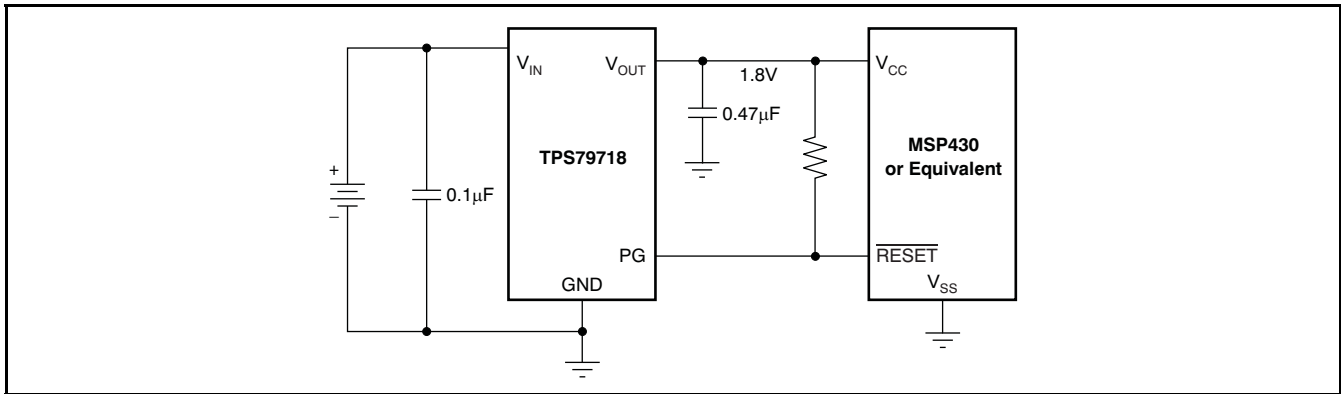

Figure 15. MSP430 Microcontroller Powered by the TPS79718 Regulator

PACKAGING INFORMATION

Orderable Device	Status ⁽¹⁾	Package Type	Package Drawing	Pins	Package Qty	Eco Plan ⁽²⁾	Lead/Ball Finish	MSL Peak Temp ⁽³⁾
TPS79718DCKR	ACTIVE	SC70	DCK	5	3000	Green (RoHS & no Sb/Br)	CU NIPDAU	Level-1-260C-UNLIM
TPS79718DCKRG4	ACTIVE	SC70	DCK	5	3000	Green (RoHS & no Sb/Br)	CU NIPDAU	Level-1-260C-UNLIM
TPS79718DCKT	ACTIVE	SC70	DCK	5	250	Green (RoHS & no Sb/Br)	CU NIPDAU	Level-1-260C-UNLIM
TPS79718DCKTG4	ACTIVE	SC70	DCK	5	250	Green (RoHS & no Sb/Br)	CU NIPDAU	Level-1-260C-UNLIM
TPS79730DCKR	ACTIVE	SC70	DCK	5	3000	Green (RoHS & no Sb/Br)	CU NIPDAU	Level-1-260C-UNLIM
TPS79730DCKRG4	ACTIVE	SC70	DCK	5	3000	Green (RoHS & no Sb/Br)	CU NIPDAU	Level-1-260C-UNLIM
TPS79730DCKT	ACTIVE	SC70	DCK	5	250	Green (RoHS & no Sb/Br)	CU NIPDAU	Level-1-260C-UNLIM
TPS79730DCKTG4	ACTIVE	SC70	DCK	5	250	Green (RoHS & no Sb/Br)	CU NIPDAU	Level-1-260C-UNLIM
TPS79733DCKR	ACTIVE	SC70	DCK	5	3000	Green (RoHS & no Sb/Br)	CU NIPDAU	Level-1-260C-UNLIM
TPS79733DCKRG4	ACTIVE	SC70	DCK	5	3000	Green (RoHS & no Sb/Br)	CU NIPDAU	Level-1-260C-UNLIM
TPS79733DCKT	ACTIVE	SC70	DCK	5	250	Green (RoHS & no Sb/Br)	CU NIPDAU	Level-1-260C-UNLIM
TPS79733DCKTG4	ACTIVE	SC70	DCK	5	250	Green (RoHS & no Sb/Br)	CU NIPDAU	Level-1-260C-UNLIM

⁽¹⁾ The marketing status values are defined as follows:

ACTIVE: Product device recommended for new designs.

LIFEBUY: TI has announced that the device will be discontinued, and a lifetime-buy period is in effect.

NRND: Not recommended for new designs. Device is in production to support existing customers, but TI does not recommend using this part in a new design.

PREVIEW: Device has been announced but is not in production. Samples may or may not be available.

OBSOLETE: TI has discontinued the production of the device.

⁽²⁾ Eco Plan - The planned eco-friendly classification: Pb-Free (RoHS), Pb-Free (RoHS Exempt), or Green (RoHS & no Sb/Br) - please check <http://www.ti.com/productcontent> for the latest availability information and additional product content details.

TBD: The Pb-Free/Green conversion plan has not been defined.

Pb-Free (RoHS): TI's terms "Lead-Free" or "Pb-Free" mean semiconductor products that are compatible with the current RoHS requirements for all 6 substances, including the requirement that lead not exceed 0.1% by weight in homogeneous materials. Where designed to be soldered at high temperatures, TI Pb-Free products are suitable for use in specified lead-free processes.

Pb-Free (RoHS Exempt): This component has a RoHS exemption for either 1) lead-based flip-chip solder bumps used between the die and package, or 2) lead-based die adhesive used between the die and leadframe. The component is otherwise considered Pb-Free (RoHS compatible) as defined above.

Green (RoHS & no Sb/Br): TI defines "Green" to mean Pb-Free (RoHS compatible), and free of Bromine (Br) and Antimony (Sb) based flame retardants (Br or Sb do not exceed 0.1% by weight in homogeneous material)

⁽³⁾ MSL, Peak Temp. -- The Moisture Sensitivity Level rating according to the JEDEC industry standard classifications, and peak solder temperature.

Important Information and Disclaimer: The information provided on this page represents TI's knowledge and belief as of the date that it is provided. TI bases its knowledge and belief on information provided by third parties, and makes no representation or warranty as to the accuracy of such information. Efforts are underway to better integrate information from third parties. TI has taken and continues to take reasonable steps to provide representative and accurate information but may not have conducted destructive testing or chemical analysis on incoming materials and chemicals. TI and TI suppliers consider certain information to be proprietary, and thus CAS numbers and other limited information may not be available for release.

In no event shall TI's liability arising out of such information exceed the total purchase price of the TI part(s) at issue in this document sold by TI to Customer on an annual basis.

OTHER QUALIFIED VERSIONS OF TPS79718, TPS79730, TPS79733 :

- Automotive: [TPS79718-Q1](#), [TPS79730-Q1](#), [TPS79733-Q1](#)
- Enhanced Product: [TPS79718-EP](#), [TPS79730-EP](#), [TPS79733-EP](#)

NOTE: Qualified Version Definitions:

- Automotive - Q100 devices qualified for high-reliability automotive applications targeting zero defects
- Enhanced Product - Supports Defense, Aerospace and Medical Applications

TAPE AND REEL INFORMATION

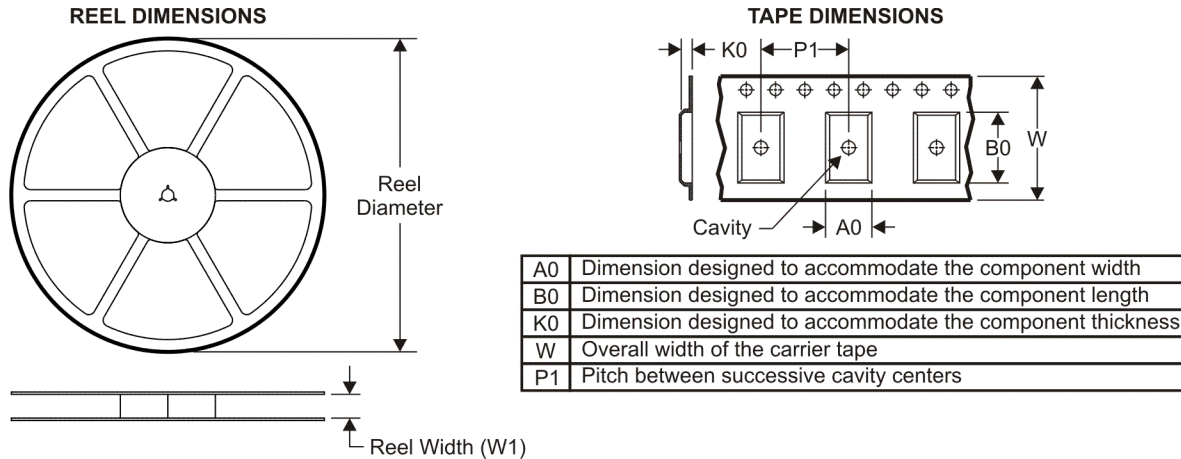

QUADRANT ASSIGNMENTS FOR PIN 1 ORIENTATION IN TAPE



*All dimensions are nominal

Device	Package Type	Package Drawing	Pins	SPQ	Reel Diameter (mm)	Reel Width W1 (mm)	A0 (mm)	B0 (mm)	K0 (mm)	P1 (mm)	W (mm)	Pin1 Quadrant
TPS79718DCKR	SC70	DCK	5	3000	180.0	9.2	2.24	1.22	2.34	4.0	8.0	Q3
TPS79718DCKT	SC70	DCK	5	250	180.0	9.2	2.24	1.22	2.34	4.0	8.0	Q3
TPS79730DCKR	SC70	DCK	5	3000	180.0	9.2	2.24	1.22	2.34	4.0	8.0	Q3
TPS79730DCKT	SC70	DCK	5	250	180.0	9.2	2.24	1.22	2.34	4.0	8.0	Q3
TPS79733DCKR	SC70	DCK	5	3000	180.0	9.2	2.24	1.22	2.34	4.0	8.0	Q3
TPS79733DCKT	SC70	DCK	5	250	180.0	9.2	2.24	1.22	2.34	4.0	8.0	Q3

TAPE AND REEL BOX DIMENSIONS



*All dimensions are nominal

Device	Package Type	Package Drawing	Pins	SPQ	Length (mm)	Width (mm)	Height (mm)
TPS79718DCKR	SC70	DCK	5	3000	180.0	180.0	85.0
TPS79718DCKT	SC70	DCK	5	250	180.0	180.0	85.0
TPS79730DCKR	SC70	DCK	5	3000	180.0	180.0	85.0
TPS79730DCKT	SC70	DCK	5	250	180.0	180.0	85.0
TPS79733DCKR	SC70	DCK	5	3000	180.0	180.0	85.0
TPS79733DCKT	SC70	DCK	5	250	180.0	180.0	85.0

DCK (R-PDSO-G5)

PLASTIC SMALL-OUTLINE PACKAGE



- NOTES:
- A. All linear dimensions are in millimeters.
 - B. This drawing is subject to change without notice.
 - C. Body dimensions do not include mold flash or protrusion. Mold flash and protrusion shall not exceed 0.15 per side.
 - D. Falls within JEDEC MO-203 variation AA.

IMPORTANT NOTICE

Texas Instruments Incorporated and its subsidiaries (TI) reserve the right to make corrections, modifications, enhancements, improvements, and other changes to its products and services at any time and to discontinue any product or service without notice. Customers should obtain the latest relevant information before placing orders and should verify that such information is current and complete. All products are sold subject to TI's terms and conditions of sale supplied at the time of order acknowledgment.

TI warrants performance of its hardware products to the specifications applicable at the time of sale in accordance with TI's standard warranty. Testing and other quality control techniques are used to the extent TI deems necessary to support this warranty. Except where mandated by government requirements, testing of all parameters of each product is not necessarily performed.

TI assumes no liability for applications assistance or customer product design. Customers are responsible for their products and applications using TI components. To minimize the risks associated with customer products and applications, customers should provide adequate design and operating safeguards.

TI does not warrant or represent that any license, either express or implied, is granted under any TI patent right, copyright, mask work right, or other TI intellectual property right relating to any combination, machine, or process in which TI products or services are used. Information published by TI regarding third-party products or services does not constitute a license from TI to use such products or services or a warranty or endorsement thereof. Use of such information may require a license from a third party under the patents or other intellectual property of the third party, or a license from TI under the patents or other intellectual property of TI.

Reproduction of TI information in TI data books or data sheets is permissible only if reproduction is without alteration and is accompanied by all associated warranties, conditions, limitations, and notices. Reproduction of this information with alteration is an unfair and deceptive business practice. TI is not responsible or liable for such altered documentation. Information of third parties may be subject to additional restrictions.

Resale of TI products or services with statements different from or beyond the parameters stated by TI for that product or service voids all express and any implied warranties for the associated TI product or service and is an unfair and deceptive business practice. TI is not responsible or liable for any such statements.

TI products are not authorized for use in safety-critical applications (such as life support) where a failure of the TI product would reasonably be expected to cause severe personal injury or death, unless officers of the parties have executed an agreement specifically governing such use. Buyers represent that they have all necessary expertise in the safety and regulatory ramifications of their applications, and acknowledge and agree that they are solely responsible for all legal, regulatory and safety-related requirements concerning their products and any use of TI products in such safety-critical applications, notwithstanding any applications-related information or support that may be provided by TI. Further, Buyers must fully indemnify TI and its representatives against any damages arising out of the use of TI products in such safety-critical applications.

TI products are neither designed nor intended for use in military/aerospace applications or environments unless the TI products are specifically designated by TI as military-grade or "enhanced plastic." Only products designated by TI as military-grade meet military specifications. Buyers acknowledge and agree that any such use of TI products which TI has not designated as military-grade is solely at the Buyer's risk, and that they are solely responsible for compliance with all legal and regulatory requirements in connection with such use.

TI products are neither designed nor intended for use in automotive applications or environments unless the specific TI products are designated by TI as compliant with ISO/TS 16949 requirements. Buyers acknowledge and agree that, if they use any non-designated products in automotive applications, TI will not be responsible for any failure to meet such requirements.

Following are URLs where you can obtain information on other Texas Instruments products and application solutions:

Products

Amplifiers	amplifier.ti.com
Data Converters	dataconverter.ti.com
DSP	dsp.ti.com
Clocks and Timers	www.ti.com/clocks
Interface	interface.ti.com
Logic	logic.ti.com
Power Mgmt	power.ti.com
Microcontrollers	microcontroller.ti.com
RFID	www.ti-rfid.com
RF/IF and ZigBee® Solutions	www.ti.com/lprf

Applications

Audio	www.ti.com/audio
Automotive	www.ti.com/automotive
Broadband	www.ti.com/broadband
Digital Control	www.ti.com/digitalcontrol
Medical	www.ti.com/medical
Military	www.ti.com/military
Optical Networking	www.ti.com/opticalnetwork
Security	www.ti.com/security
Telephony	www.ti.com/telephony
Video & Imaging	www.ti.com/video
Wireless	www.ti.com/wireless

Mailing Address: Texas Instruments, Post Office Box 655303, Dallas, Texas 75265
Copyright © 2008, Texas Instruments Incorporated